

OVERVIEW - PFC FLATPAC

The PFC FlatPAC consists of a universal input (85-264 Vac) AC front end and one Maxi DC-DC converter in an integrated mechanical assembly providing up to 575 W of power. Using Vicor’s Harmonic Attenuator Module (HAM) and integrated filtering, the PFC FlatPAC meets EN61000-3-2 harmonic current limits and 0.99 power factor. The internal filtering provides compliance to EN55022-A conducted EMI.

The PFC FlatPAC will accept an input voltage of 85-264 Vac, derate power at 9 W/Vrms as shown in Figure 19–1.

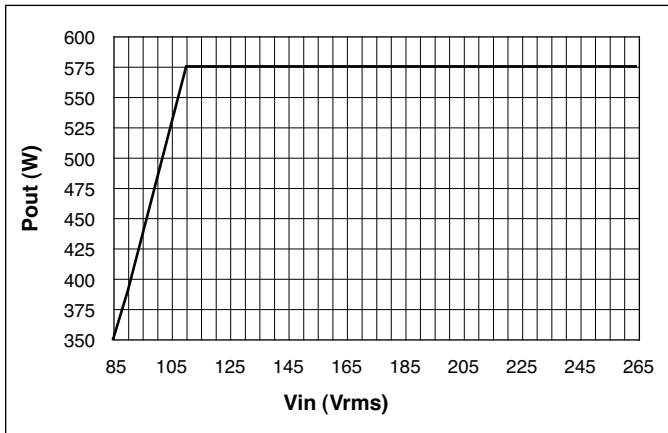

Figure 19–1 — PFC FlatPAC output power vs. input voltage

CIRCUIT OPERATION

AC line voltage is applied via an agency-approved terminal block providing AC mains (L1, L2/N and GND). Current in the L1 lead is applied to a 15 A / 250 V internal fuse. This current is interrupted only in the event of a catastrophic failure of a main power component internal to the PFC FlatPAC.

The input current beyond the fuse is passed through an EMC filter designed to meet conducted noise limits of FCC Part 15 EN55022 Class A. At start-up, AC inrush current is limited by the HAM’s internal circuitry prior to being passed to the main energy storage capacitors.

The DC-DC converter is held off until the internal DC bus potential has settled to full operating level. The converter is then enabled.

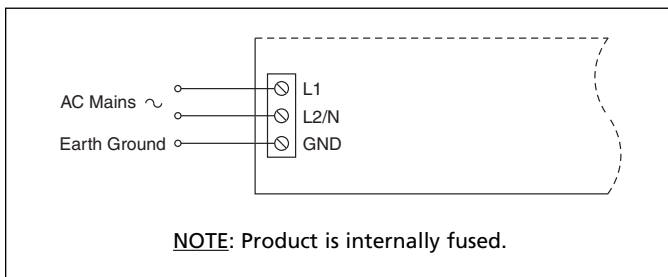

Figure 19–2 — AC mains connections

Fusing. The PFC FlatPAC’s internal fuse is not user-replaceable.

Grounding. To satisfy IEC950 Class I grounding requirements, connect a ground lead to the terminal marked (GND). Use 2.5 mm² / #14 AWG wire.

Input Voltage Connections. Connect the line voltage to L1 (hot) and L2N (neutral). Use #14AWG input wire. Recommended connector screw torque is 5 to 7 in-lbs (0.5 to 0.8 N-m). Recommended strip length is 8 mm. Refer to Figure 19–2.

Output Wire Gauge. Use the output wire gauge that corresponds to the output current of your FlatPAC unit, below: Do not loosen bottom nut. Long cable runs, or wires in large bundles will require heavier cable to avoid excessive voltage drops or overheating.

100 A–160 A : #2 AWG	30 A–50 A : #8 AWG	10 A–15 A : #14 AWG
75 A–100 A : #4 AWG	20 A–30 A : #10 AWG	6 A–10 A : #16 AWG
50 A–75 A : #6 AWG	15 A–20 A : #12 AWG	0 A–6 A : #18 AWG

Table 19–1

Output Voltage Trimming. The Maxi converters used in the PFC FlatPAC have a wide trim range of +10% to -90%. See the Maxi, Mini, Micro design guide for details.

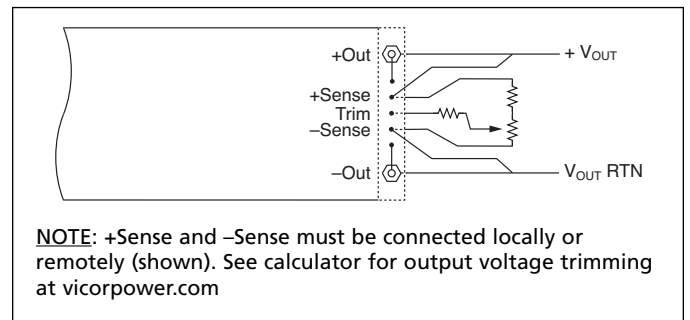

Figure 19–3 — Output sense and trim

Operating Temperature. Do not allow the PFC FlatPAC to exceed its maximum operating temperature, which is reached when the heat sink is 85°C. (Full power can be delivered up to this temperature.) Heat sink temperature is a function of the output power and voltage of the supply, ambient temperature, and airflow across the heat sink. Always use worst-case conditions when calculating operating temperature.

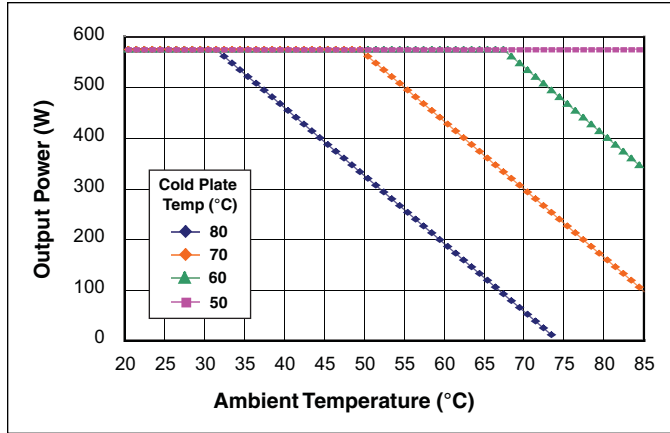

Figure 19-4 — Power de-rating conduction cooled option

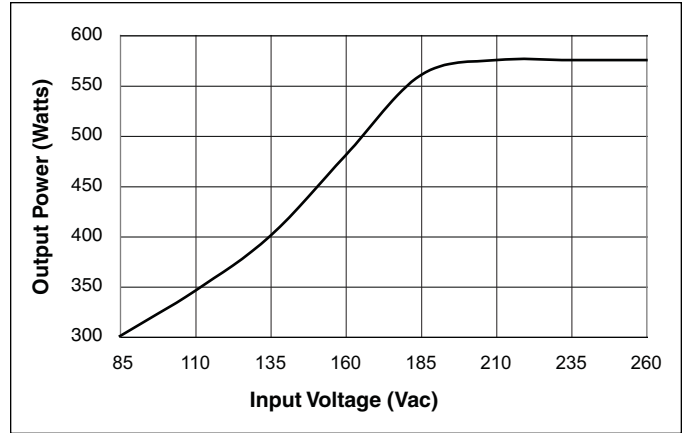

Figure 19-5 — Output power start-up de-rating @ -30° C (I-Grade only). 5 minute warm up required before full power (see Figure 19-1) is available.

NOTE 1: To ensure proper heat transfer from the internal modules to the heat sink, the mounting holes through the heat sink (three holes on 2-up models) must contain torqued screws at all times during operation, whether or not the unit is mounted. If the unit is operated unmounted, insert a #6 or M3.5 panhead screw through each hole from below and secure with a nut on top, torqued to 6 in-lbs (0.7 N-m).

NOTE 2: All PFC FlatPAC models are available with a conduction cooled flat plate instead of the top heat sink. Go to vicorpower.com for outline drawings. Refer to Figure 19-4 for additional deratings for the -cc variants.