

OVERVIEW

In combination with VI-200 and VI-J00 Family of DC-DC converter modules, the Alternating Input Module (AIM) provides a high density, low profile, universal AC input off-line switching power supply for systems requiring up to 200 W of total output power. The AIM accepts 85 – 264 Vac, with a DC output voltage proportional to the peak value of the AC line. The input voltage required for the AIM to start operating is between 82 V and 90 Vrms (non-distorted sinusoid).

The DC output of the AIM is the peak rectified line ($V_{ac} \text{ RMS} \times \sqrt{2}$), thus, 85 Vac corresponds to 120 Vdc and 264 Vac corresponds to 373 Vdc. Since the DC output range is wide, a “7” (100 – 375 V) designator for input voltage in the part number of the DC-DC converter is required. However, the “5” (100 – 200 V) designator for the DC-DC converter part number is available for domestic AC inputs only and the “6” (200 – 400 V) designator for European AC inputs only, potentially reducing the number of modules required in some applications, based on output power capability.

SUMMARY OF COMPATIBLE DOWNSTREAM DC-DC CONVERTERS

Use VI-x7x for inputs of 85–264 Vac; VI-x6x for inputs of 170–264 Vac; or VI-x5x for inputs of 85–135 Vac. EMC filtering specifications of FCC Level A are met by adding a 0.47 μF “X-type” capacitor to the input of the AIM (Vicor Part #03047); “Y-type” bypass capacitors must also be added from the +/- inputs of the DC-DC converters to their respective baseplates, which are grounded (Vicor Part #01000, 4,700 pF). To select the hold-up capacitor appropriate for your application, (refer to Selecting Capacitors for AIM Modules section that follows).

The output ripple of the AIM is a function of output load. It is necessary to keep the ripple less than 20 V p-p to ensure the under / overvoltage protection circuits will not trigger. A fully loaded AIM (200 W of module output power) requires a minimum of 680 μF of capacitance; hold-up requirements can be met with this capacitor and maximum total capacitance should not exceed 1,200 μF (refer to Selecting Capacitors for AIM Modules section that follows). The voltage rating of this capacitor will be determined by the input operating voltage.

It is necessary to connect all “Driver” DC-DC converter GATE IN pins to the GATE IN pin of the AIM. This GATE IN to GATE IN connection is used to disable the converters at turn-on to allow proper start-up of the AIM. The DC-DC converters are then enabled through the GATE IN pin when the output bus voltage is in the range of 113 – 123 Vdc.

Input overvoltage conditions cause the GATE IN pin of the AIM to disable the converters when the output bus voltage is in the range of 406 – 423 Vdc. Input undervoltage conditions cause the GATE IN to disable the converters when the output bus voltage drops within the range of 68 – 89 Vdc.

CAUTION: The AIM is not isolated. Do not place scope probes on input and output of AIM simultaneously. Do not connect the output of the AIM to earth ground.

The GATE OUT of the AIM must be connected to the GATE OUT of only one DC-DC converter. This input signal to the AIM controls a charge pump (D1, D2, C2) that biases the gate of Q1, 10 V above its source, which turns on Q1 to shunt out a PTC thermistor that limits inrush. Multiple DC-DC converters operating from an AIM may make it difficult to guarantee a 10% load on the DC-DC converter that provides the GATE OUT signal to the AIM. In this instance, other DC-DC converters can charge pump the FET through the PARALLEL pin, with the addition of two diodes and a capacitor to each Driver module. (Figure 12–4)

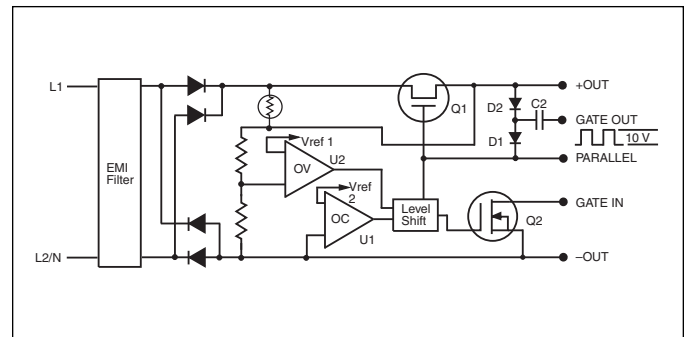
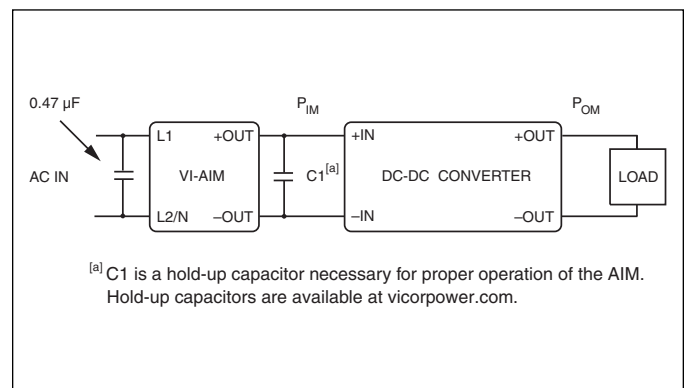

Figure 12–1 — Block diagram, AIM / MI-AIM



^[a] C1 is a hold-up capacitor necessary for proper operation of the AIM. Hold-up capacitors are available at vicorpower.com.

Figure 12–2 — System block diagram (supervisory connections not shown)

SELECTING CAPACITORS FOR AIM MODULES

Hold-up Time. For maximum flexibility, an external capacitor (Figure 12–2, C1) is used to set the system's hold-up requirements. Hold-up time, for purposes of this application note, is defined as the time interval from loss of AC power to the time a DC-DC converter begins to drop out of regulation (Figure 12–3, T4 to T5). Hold-up time is a function of line voltage, hold-up capacitance, output load, and that point on the AC waveform where the line drops out. For example, if the AC line fails just after the hold-up capacitors were recharged, hold-up time will be much greater (Figure 12–3, T3 to T5) than if the AC line fails just prior to another recharge (Figure 12–3, T4 to T5).

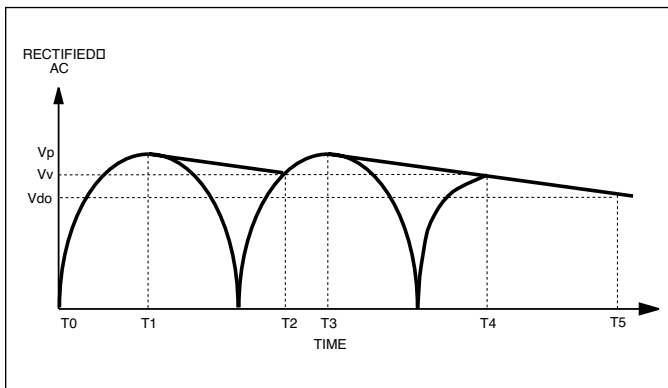

Figure 12–3 — AC waveforms

The basic equations involved in calculating hold-up time are:

$$\frac{1}{2} \times C1 \times Vp^2 - \frac{1}{2} \times C1 \times Vdo^2 = P_{IM} \times (T5 - T3) \quad (1)$$

solving for C1:

$$C1 = 2 \times \frac{P_{IM} \times (T5 - T3)}{Vp^2 - Vdo^2} \quad (2)$$

Where P_{IM} is power delivered from the AIM:

$$P_{IM} = \frac{\text{Module Output Power}}{\text{Module Efficiency}} = \frac{P_{OM}}{\text{Eff. \%} / 100} \quad (3)$$

The energy (Joules) delivered from the AIM from the time power is lost (T4), until loss of an output (Figure 12–2, T5):

$$\text{Energy (Joules)} = P_{IM} \times (T5 - T4) \text{ (Watt – Seconds)} \quad (4)$$

where: P_{OM} = Output power from all the modules

P_{IM} = Input power to the modules
(output power from the AIM)

Eff = Weighted average efficiency of all modules

The input power to the converter(s) during normal operation is supplied from the AC line during the conduction time of the rectifiers (T2 to T3) internal to the AIM and by the energy stored in C1 when the rectifiers in the AIM are reverse biased (T1 to T2). In the event of an AC failure (T4), C1 must continue to provide energy to the converters until either AC returns or the converter drops out (T5).

The energy stored in C1 at the peak of the AC is:

$$\frac{1}{2} \times C1 \times Vp^2 = \text{Joules} \quad (5)$$

The energy stored in C1 when the converter drops out of regulation is:

$$\frac{1}{2} \times C1 \times Vdo^2 = \text{Joules} \quad (6)$$

The energy delivered by C1 to the converters during normal operation is:

$$P_{IM} \times (T2 - T1) = \text{Joules} \quad (7)$$

CHOOSING APPROPRIATE VALUES FOR AIM MODULES

Sample calculation:

Converter output power (P_{OM}) = 100 W

Line frequency = 60 Hz

Line range = 105 – 264 Vac

Efficiency = 82%

Desired hold-up time = 5 ms (minimum)

therefore:

$$P_{IM} = \frac{100}{0.82} = 122 \text{ W}$$

$T5 - T3 = 5 \text{ ms} + 8.3 \text{ ms} = 13.3 \text{ ms}$
(minimum hold-up time plus half cycle)

$V_p = 105 \times \sqrt{2} = 148 \text{ V}$

$V_{do} = 100 \text{ V}$

and:

$$C1 = \frac{2 \times 122 \times 0.0133}{148^2 - 100^2}$$

$C1 = 270 \mu\text{F}$

where:

V_p = The peak of the rectified AC line or $\sqrt{2} \times V_{ac\text{in}}$.
For an input range of 85 – 264 Vac, this voltage will vary from 120 – 373 V.

V_v = The low point of the rectified AC line under normal operating conditions. This “valley” voltage is a function of C1, P_{IM} and line frequency. The peak-to-peak ripple across C1 is $V_p - V_v$ and determines the ripple current in C1.

NOTE: It is important to verify the rms ripple current in C1 with a current probe.

V_{do} = Voltage at which the DC-DC converter(s) begin(s) to drop out of regulation. This voltage is from the data sheet of the appropriate module, which for the VI-270 Family is 100 Vdc. Under normal operating conditions, V_v must exceed V_{do} .

T1 = The peak of the rectified AC line or the point at which C1 is fully charged. For an input range of 85 – 264 Vac, this voltage will vary from 120 – 373 V.

T2 = The low point of the rectified AC line under normal operating conditions and the point at which C1 is about to be “recharged”. This is the point of lowest energy in C1.

T4 = The low point of the rectified AC line; the point of lowest energy in C1; the point at which if the AC line fails, hold-up time is shortest, i.e., “worst case”.

T5 = The time at which the converter(s) drop out of regulation.

$T5 - T4$ = Minimum hold-up time. Actual hold-up time may vary up to a maximum of $T5 - T3$.

$(T3 - T1) \times 2$ = One line cycle.

The following values are calculated in a similar manner.

Module(s) Delivered Power	60 Hz		50 Hz	
	90 Vac	105 Vac	90 Vac	105 Vac
50 W	270 μF	135 μF	300 μF	150 μF
75 W	400 μF	200 μF	440 μF	230 μF
100 W	525 μF	270 μF	600 μF	300 μF
150 W	800 μF	400 μF	890 μF	455 μF
200 W	1,000 μF	540 μF	1,180 μF	600 μF

Table 12-1 — Hold-up capacitor values for use with VI-270/VI-J70 and the VI-250/VI-J50 DC-DC converters.

C1 values as a function of line voltage, frequency and delivered power, for use with the “7” input designator DC-DC converters (AIM input of 90–264 Vac) or “5” input designator (AIM input of 90–132 Vac) DC-DC converters.

NOTE: With “7” input DC-DC converters operated from the AIM input range of 90 – 264 Vac, 400 V capacitors must be used (Vicor Part #30240). With “5” input DC-DC converters used over the AIM input range of 90 – 132 Vac, 200 V capacitors may be used (Vicor Part #30769).

Module(s) Delivered Power	60 Hz		50 Hz	
	180 Vac	210 Vac	180 Vac	210 Vac
50 W	66 μF	34 μF	74 μF	38 μF
75 W	100 μF	50 μF	110 μF	60 μF
100 W	130 μF	67 μF	150 μF	75 μF
150 W	200 μF	100 μF	220 μF	115 μF
200 W	262 μF	135 μF	300 μF	150 μF

Table 12-1 — Hold-up capacitor values for use with VI-260/VI-J60 DC-DC converters.

C1 values as a function of line voltage, frequency and delivered power, for use with the “6” input designator DC-DC converters (AIM input of 180 – 264 Vac).

NOTE: With “6” input DC-DC converters operated from the AIM input range of 180 – 264 Vac, 400 V capacitors must be used (Vicor Part #30240).

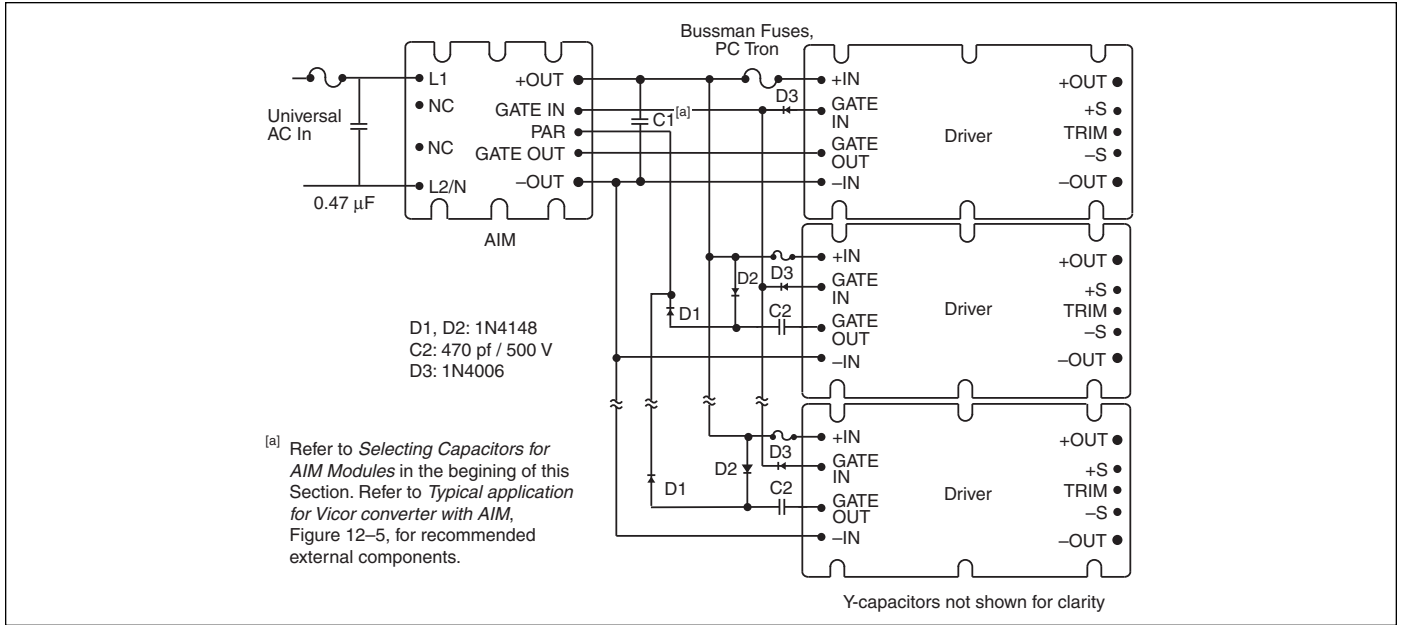

Figure 12-4 — AIM connection diagram, multiple Driver DC-DC converters

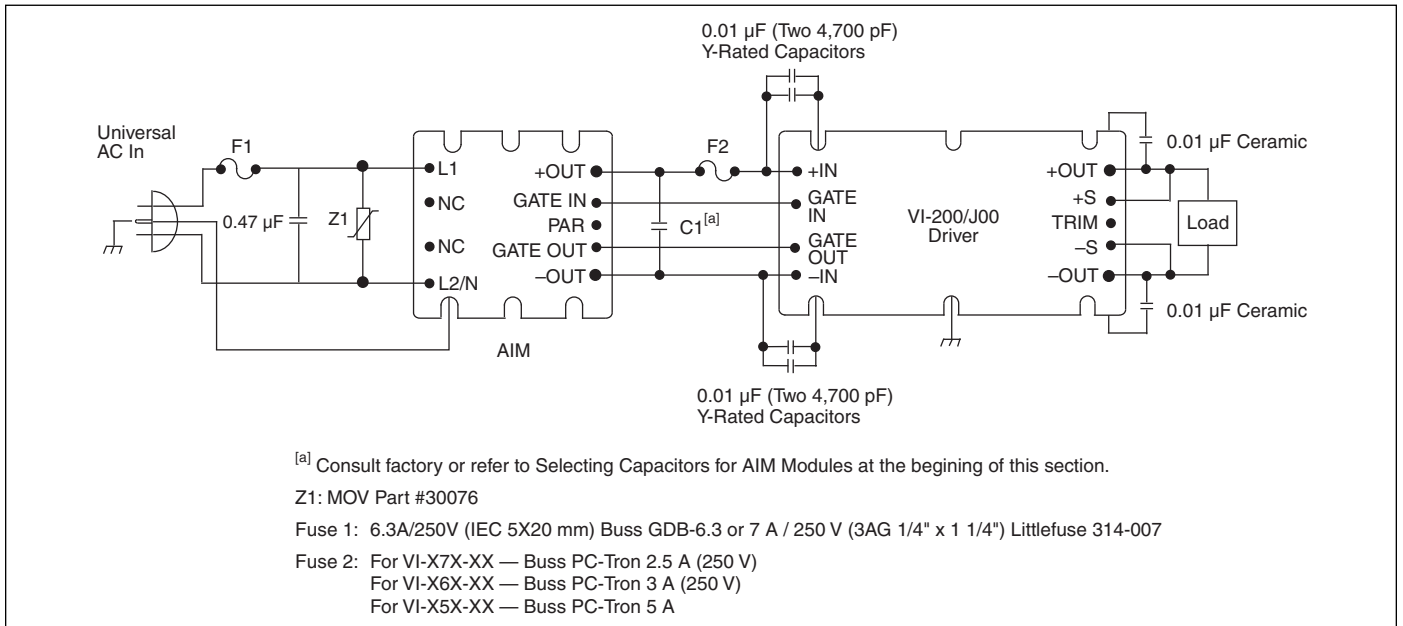

Figure 12-5 — Typical application for Vicor converter with AIM